



Installation and Operation Manual



TG-10E, -13E, and -17E Actuator

Manual 04045 (Revision E)

IMPORTANT



This is the safety alert symbol. It is used to alert you to potential personal injury hazards. Obey all safety messages that follow this symbol to avoid possible injury or death.

DEFINITIONS

- **DANGER**—Indicates a hazardous situation which, if not avoided, will result in death or serious injury.
- **WARNING**—Indicates a hazardous situation which, if not avoided, could result in death or serious injury.
- **CAUTION**—Indicates a hazardous situation which, if not avoided, could result in minor or moderate injury.
- **NOTICE**—Indicates a hazard that could result in property damage only (including damage to the control).
- **IMPORTANT**—Designates an operating tip or maintenance suggestion.

WARNING

The engine, turbine, or other type of prime mover should be equipped with an overspeed shutdown device to protect against runaway or damage to the prime mover with possible personal injury, loss of life, or property damage.

The overspeed shutdown device must be totally independent of the prime mover control system. An overtemperature or overpressure shutdown device may also be needed for safety, as appropriate.



Read this entire manual and all other publications pertaining to the work to be performed before installing, operating, or servicing this equipment. Practice all plant and safety instructions and precautions. Failure to follow instructions can cause personal injury and/or property damage.



This publication may have been revised or updated since this copy was produced. To verify that you have the latest revision, be sure to check the Woodward website:

www.woodward.com/pubs/current.pdf

The revision level is shown at the bottom of the front cover after the publication number. The latest version of most publications is available at:

www.woodward.com/publications

If your publication is not there, please contact your customer service representative to get the latest copy.



Any unauthorized modifications to or use of this equipment outside its specified mechanical, electrical, or other operating limits may cause personal injury and/or property damage, including damage to the equipment. Any such unauthorized modifications: (i) constitute "misuse" and/or "negligence" within the meaning of the product warranty thereby excluding warranty coverage for any resulting damage, and (ii) invalidate product certifications or listings.

NOTICE

To prevent damage to a control system that uses an alternator or battery-charging device, make sure the charging device is turned off before disconnecting the battery from the system.

NOTICE

To prevent damage to electronic components caused by improper handling, read and observe the precautions in Woodward manual 82715, *Guide for Handling and Protection of Electronic Controls, Printed Circuit Boards, and Modules*.

Contents

REGULATORY COMPLIANCE	III
ELECTROSTATIC DISCHARGE AWARENESS	IV
CHAPTER 1. GENERAL INFORMATION.....	1
Introduction	1
Description.....	1
Optional Actuators	1
References	2
CHAPTER 2. INSTALLATION.....	3
Introduction	3
Receiving	3
Storage	3
Drive Shaft Rotation	3
Installation	4
Linkage Attachments	5
Heat Exchanger Installation (optional)	5
When is a Heat Exchanger Necessary?.....	6
Oil Supply	6
CHAPTER 3. OPERATION AND ADJUSTMENTS.....	13
Introduction	13
Initial Operation	13
Cleaning the Filter Screens and The Pilot-Valve Plunger Orifice.....	14
Calibration Procedure.....	16
CHAPTER 4. PRINCIPLES OF OPERATION	21
Introduction	21
Component Operation	21
Operation of the TG Actuator	23
CHAPTER 5. TROUBLESHOOTING	26
Introduction	26
Visual Inspection	26
CHAPTER 6. REPLACEMENT PARTS	29
CHAPTER 7. SERVICE OPTIONS	31
Product Service Options.....	31
Woodward Factory Servicing Options	32
Returning Equipment for Repair.....	33
Replacement Parts	33
Engineering Services.....	34
How to Contact Woodward.....	34
Technical Assistance.....	35
DECLARATIONS.....	36

Illustrations and Tables

Figure 1-1. TG Actuator2
Figure 2-1. Recommended Terminal Shaft Travel5
Figure 2-2. Heat Exchanger Piping Connections6
Figure 2-3. TG Actuator Outline Drawing10
Figure 2-4. TG-13E/-17E Outline Drawing11
Figure 2-5. TG-13E/-17E Outline Drawing12
Figure 3-1. TG Actuator with Cover Removed15
Figure 3-2. Wiring Diagram for Actuator Calibration Circuit17
Figure 4-1. TG Actuator Schematic Diagram24
Figure 5-1. Actuator Test Circuit.....27
Figure 6-1. TG Exploded View30

Table 2-1. Oil Chart9
Table 2-2. Viscosity Comparisons9
Table 5-1. TG Actuator Troubleshooting28

Regulatory Compliance

European Compliance:

Machinery Directive: Compliance as a component with 98/37/EC COUNCIL DIRECTIVE of 23 July 1998 on the approximation of the laws of the Member States relating to machinery.

North American Compliance:

UL: UL Listed for Class I, Division 2, Groups B, C, & D. For use in the United States.
UL File E158654

The TG Actuator is suitable for use in Class I, Division 2, Groups B, C, and D per UL for the US or non-hazardous locations only. These listings are limited only to those units bearing the UL logo.

Wiring must be in accordance with North American Class I, Division 2 wiring methods as applicable, and in accordance with the authority having jurisdiction.

For use in NEC Class 2 circuits, 30 volts maximum.



EXPLOSION HAZARD—Do not remove covers or connect/disconnect electrical connectors unless power has been switched off or the area is known to be non-hazardous.

Substitution of components may impair suitability for Class I, Division 2.



RISQUE D'EXPLOSION—Ne pas enlever les couvercles, ni raccorder/débrancher les prises électriques, sans vous en assurer auparavant que le système a bien été mis hors tension; ou que vous vous situez bien dans une zone non explosive.

La substitution de composants peut rendre ce matériel inacceptable pour les emplacements de Classe I, Division 2.

Electrostatic Discharge Awareness

All electronic equipment is static-sensitive, some components more than others. To protect these components from static damage, you must take special precautions to minimize or eliminate electrostatic discharges.

Follow these precautions when working with or near the control.

1. Before doing maintenance on the electronic control, discharge the static electricity on your body to ground by touching and holding a grounded metal object (pipes, cabinets, equipment, etc.).
2. Avoid the build-up of static electricity on your body by not wearing clothing made of synthetic materials. Wear cotton or cotton-blend materials as much as possible because these do not store static electric charges as much as synthetics.
3. Keep plastic, vinyl, and Styrofoam materials (such as plastic or Styrofoam cups, cup holders, cigarette packages, cellophane wrappers, vinyl books or folders, plastic bottles, and plastic ash trays) away from the control, the modules, and the work area as much as possible.
4. Do not remove the printed circuit board (PCB) from the control cabinet unless absolutely necessary. If you must remove the PCB from the control cabinet, follow these precautions:
 - Do not touch any part of the PCB except the edges.
 - Do not touch the electrical conductors, the connectors, or the components with conductive devices or with your hands.
 - When replacing a PCB, keep the new PCB in the plastic antistatic protective bag it comes in until you are ready to install it. Immediately after removing the old PCB from the control cabinet, place it in the antistatic protective bag.

NOTICE

To prevent damage to electronic components caused by improper handling, read and observe the precautions in Woodward manual 82715, *Guide for Handling and Protection of Electronic Controls, Printed Circuit Boards, and Modules*.

Chapter 1.

General Information

Introduction

This manual 04045 provides general information, installation, operation, principles of operation, and troubleshooting for the Woodward TG-10E, TG-13E, and TG-17E Actuators.

All actuators have the same mounting pad, drive shaft configuration, and terminal shafts.

Rated work capacity is 10 lb-ft (14 N·m) for the TG-10E and 13 lb-ft (18 N·m) for the TG-13E, both with 150 psi (1034 kPa) internal operating oil pressure. The TG-17E offers 18 lb-ft (24 N·m) rated work capacity with higher 200 psi (1379 kPa) oil operating pressure.

Maximum terminal shaft travel for the TG-10E is 30 degrees, and 40 degrees for the TG-13E/-17E. Recommended travel from “NO LOAD” to “FULL LOAD” is 2/3 of maximum terminal shaft travel, or 20 degrees for the TG-10E, and 30 degrees for the TG-13E/-17E. (See Figure 2-1, Recommended Terminal Shaft Travel.)

The internal pump is sized to operate over standard speed ranges: 1100 to 2400 rpm; 2400 to 4000 rpm; 4000 to 6000 rpm. The actuator is built for the speed range specified by the customer. The high-speed actuator (4000 to 6000 rpm) may require a heat exchanger in some applications. (See Chapter 2, When is a Heat Exchanger Necessary?)

All other operating features and specifications of the TG actuators are the same for each model.

Description

The TG actuator is a self-contained, proportional, electrohydraulic actuator used for the positioning of valves. It can be used with all available Woodward integrating electronic controls and accessories.

The TG proportional electrohydraulic actuator is a transducer which converts a given electrical signal to a corresponding proportional angular output shaft position to control the flow of steam or energy medium to the turbine. The actuator is controlled by an external signal from an integrating amplifier. The control signal must be unidirectional dc, thereby proportionally increasing the mechanical output position. The exact control used depends upon the operating scheme of the installation. Control assemblies are available to control speed, frequency, load, pressure, and other variables.

Optional Actuators

A TG actuator is available which does not require a drive from the turbine (Figure 2-4). It uses an external, customer-supplied, hydraulic source and can be located in a convenient location to operate the steam valve linkage.

Also available is an electric motor-driven TG actuator (Figure 2-5) which can be mounted in a convenient location and does not require a mechanical drive from the turbine or an external oil supply.

A UL Listed TG (Class I, Division 2, Groups B, C, and D), is also available for use in hazardous areas.

References

The following Woodward publications may prove useful:

Number	Title
04044	Product Specification, TG-13E & -17E Actuator
25071	Oils for Hydraulic Controls
25075	Commercial Preservation Packaging for Storage of Mechanical-Hydraulic Controls
36641	Governor Oil Heat Exchanger
50055	Service Bulletin, TG Actuators. Transducer Tightness Check

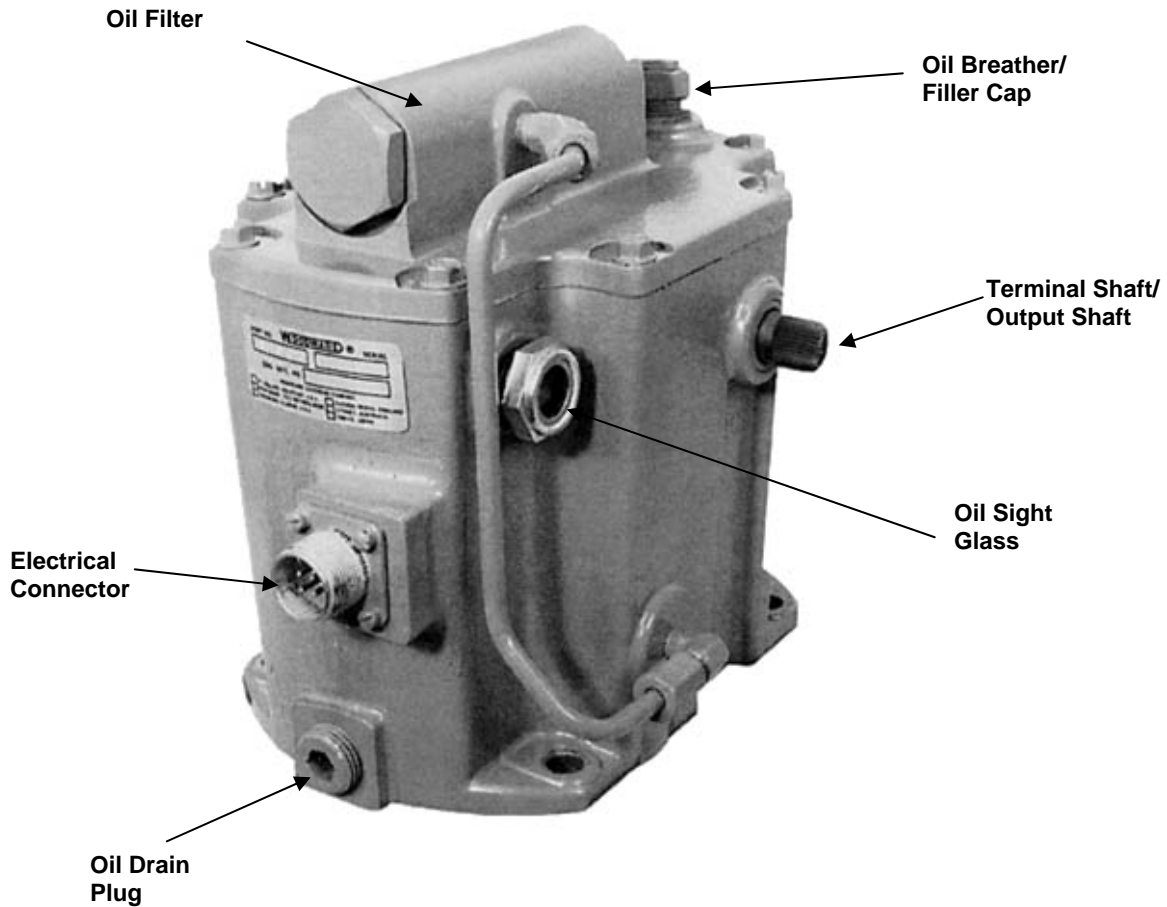

Figure 1-1. TG Actuator

Chapter 2. Installation

Introduction

This chapter describes receiving, storage, and installation requirements for the TG actuator.

Use care while handling and installing the TG actuator. Be particularly careful to avoid striking the drive shaft, terminal shafts, or the electrical connector. Abuse can damage seals, internal parts, and factory adjustments. Do not rest the actuator on its drive shaft.

Receiving

The TG actuator is shipped from the factory boxed and bolted to a wooden platform in the vertical position. The oil sight gauges are factory installed on the sides of the case, and a breather/filler cap is positioned on the cover for vertical or horizontal actuator mounting and operation.

After factory testing and adjusting, the TG actuator is drained of oil, sealed, and painted. This leaves a light film of oil covering internal parts to prevent rust. External shafts are coated with a spray lubricant. No internal cleaning or flushing is necessary before installation and operation.

Storage

The TG actuator may be stored for short periods of time as received from the factory. For long-term storage, storage in an environment with large temperature changes, humid or corrosive atmosphere, etc., or if the actuator is installed on the turbine for storage, fill the actuator with oil and follow preservation packaging instructions in Woodward manual 25075, *Commercial Preservation Packaging for Storage of Mechanical-Hydraulic Controls*.

If the breather/filler cap has been set for horizontal governor operation and the actuator is to be stored vertically, replace the cap with a plug before filling it with oil to prevent oil from draining through the vent hole.

Drive Shaft Rotation

The actuator rotation is single rotation only. When looking at the actuator from the top, the direction of rotation must be the same as the turbine shaft or the electric motor driving the oil pump. The arrows on the actuator base indicate the actual direction of rotation, when viewing in that plane. Use the following procedure to change the direction of rotation of the oil pump:

1. Remove the four pump housing screws.
2. Rotate the pump housing assembly 180 degrees.
3. Align the arrows on the pump housing with the pointer on the actuator case. The arrows indicate the actual pump drive shaft rotation.

4. Replace the four screws and torque to 80 lb-in (9.0 N·m).
5. Make sure that the pump drive shaft rotates freely.

Maintenance of the TG actuator is minimal due to few moving parts, weatherproof design, and self-contained oil supply. The pump drive shaft operates a Gerotor-type oil pump. Internal oil pump pressure is regulated by a relief valve/accumulator. An oil sight glass is installed on both sides of the actuator case for checking oil condition and oil level.

Installation

The actuator can be installed either vertically or horizontally. Installation is called vertical or horizontal if the drive shaft is in a vertical or horizontal position when viewing the actuator installed on its mounting base. Due to gravitational forces on the transducer and resulting calibration shift, the actuator should be ordered from the factory for horizontal or vertical installation. Changing the actuator from horizontal to vertical installation, or vice versa, requires a recalibration of the actuator. See Chapter 3, Calibration Procedure with Actuator on a Test Stand OR Calibration Procedure with Actuator on the Turbine.

The breather/filler cap is factory installed on the cover for shipping. For horizontal operation, the cap and drain plug must be moved to the alternate positions. This places the servo-piston on the bottom, keeping it completely immersed in oil and preventing air from being trapped in the servo. See Figure 2-3 (Outline Drawing) for alternate cap and plug positions as well as actuator mounting hole locations and hole sizes.

IMPORTANT

For horizontal operation, the TG actuator must be installed with the oil sight gauge at the top of the actuator.

Make sure that there is adequate clearance for attaching the steam valve linkage and electrical connector and for performing oil maintenance.

The actuator requires 1/2 hp (373 W) maximum to turn the oil pump drive shaft at rated speed. A decal label on the side of the case indicates the direction of rotation when the unit was shipped from the factory.

NOTICE

Be sure turbine drive and actuator drive rotation are the same. Incorrect drive rotation may cause actuator damage.

Make sure the drive shaft turns freely before installing the TG actuator. Mount the actuator squarely on the mounting pad, installing the correct length coupling with a number 5 Woodruff key. A gasket between the actuator and mounting pad may be used. There must be no binding, side loading, or backlash in the oil pump drive. Improper alignment or too tight of a fit between parts can result in excessive wear or seizure. There must be no force pushing the pump drive shaft into the actuator. The actuator must slide onto the mounting pad by its own weight without having to apply force. Tighten the four actuator mounting bolts equally.

Linkage Attachments

The terminal shaft extends from both sides of the case and provides 30 degrees of travel for the TG-10E and 40 degrees of travel for the TG-13E/-17E. Recommended travel from "NO LOAD" to "FULL LOAD" is 2/3 of maximum terminal shaft travel (Figure 2-1).

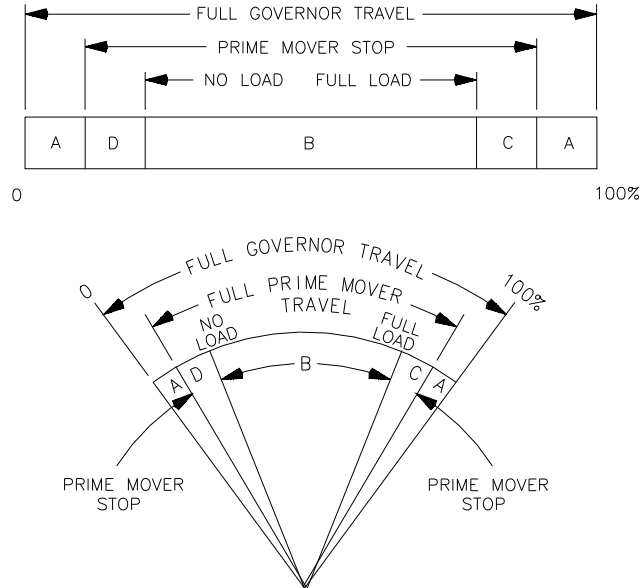

- A - OVERTRAVEL TO INSURE PRIME MOVER STOPS ARE REACHED.
- B - NO LOAD TO FULL LOAD TRAVEL - NORMALLY 2/3 OF FULL GOVERNOR TRAVEL IS RECOMMENDED.
- C - TRAVEL REQUIRED TO ACCELERATE THE PRIME MOVER.
- D - TRAVEL REQUIRED TO DECELERATE OR SHUT DOWN PRIME MOVER.

MI-153a
98-04-14 skw

Figure 2-1. Recommended Terminal Shaft Travel



WARNING

Be sure to allow sufficient overtravel at each end of the terminal shaft so that the actuator can shut down the turbine and also give maximum steam flow when required.

Installed linkages must operate smoothly, free of binding. If there is a collapsible member in the linkage, be sure that it does not yield each time the actuator moves the linkage rapidly.

Adequate locking methods must be used on the linkage connections. The terminal shaft must have a 0.625-36 serration to clamp to the output shaft of the governor.

Heat Exchanger Installation (optional)

If it is necessary to install a heat exchanger, mount it below actuator oil level in order to prevent overflow of oil through the actuator breather/filler cap. Flush the heat exchanger before installation with the same grade and type of oil selected for the TG (see information on Oil Supply below) to remove possible oxidation.

Make the required piping connections to the cooler and the actuator. See Figure 2-2 which illustrates piping connections. The cooler must be installed in the line to the cover filter.

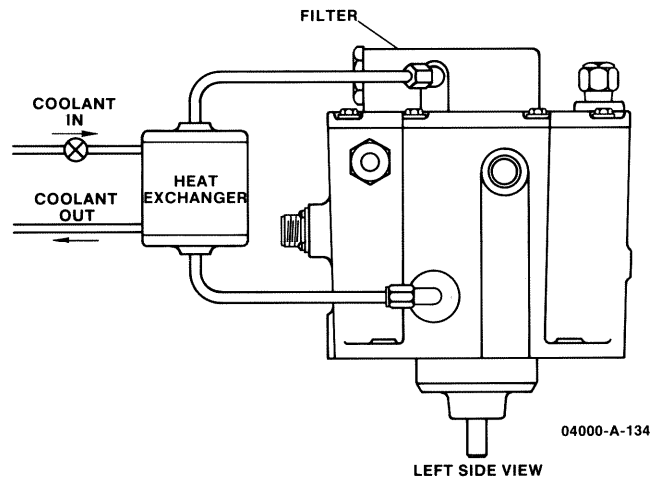

Figure 2-2. Heat Exchanger Piping Connections

Use a pipe size that minimizes pipe pressure losses to less than 15 psi (103 kPa). Oil flow from the oil to cooler inlet tap (.125-27 NPTF) is 1.0 gal/min (3.8 L/min) on an actuator operating at 6000 rpm and using a 0.250 thick Gerotor pump (0.250 is standard thickness on high rpm actuators). For the TG-17E, it is 1.2 gal/min (4.5 L/min) at 200 psi (1379 kPa).

We recommend that a throttling device be installed to the heat exchanger so that coolant flow is regulated for optimum oil temperature. Excessive cooling of actuator oil can cause sluggish operation.

When is a Heat Exchanger Necessary?

Some applications of the TG may require an oil heat exchanger be used to prevent oil breakdown and subsequent problems due to excessive oil operating temperatures. TG actuators operating at low and medium speed ranges (1100–2400 and 2400–4000 rpm) do not normally require a heat exchanger. The high speed actuator (4000 to 6000 rpm) may require a heat exchanger in some applications. Factors such as oil viscosity, actuator speed, heat radiation from surrounding sources, and mounting pad and ambient temperatures affect oil conditions, necessitating an oil cooler (see Woodward Manual 25071, *Oils for Hydraulic Controls*). Generally, when oil viscosity at operating temperature is below 100 SUS (Saybolt Universal Seconds), an oil cooler is required.

A single pass, counter-flow heat exchanger with 1 to 2 ft² (0.09 to 0.19 m²) of heat transfer area, provides adequate cooling for most high speed TG actuators. If there is doubt concerning the need for, or size of, a heat exchanger, contact Woodward. Heat exchangers can be purchased from Woodward.

Oil Supply

Use this information as a guide in the selection of a suitable lubricating/hydraulic oil (for more information on oils, refer to manual 25071).

Oil grade selection is based on the operating temperature range of the actuator. Also, use this information to aid in recognizing and correcting common problems associated with oil used in products manufactured by Woodward.

Normally, the oil recommended for the turbine by the turbine manufacturer is acceptable for use in the actuator.

Actuator oil is both a lubricating oil and a hydraulic oil. It must have a viscosity index that allows it to perform over the operating temperature range, and it must have the proper blending of additives that cause it to remain stable and predictable over this range.

Actuator oil must be compatible with seal materials (nitrile, polyacrylic, and fluorocarbon). Many automotive and gas engine oils, industrial lubricating oils, and other oils of mineral or synthetic origin meet these requirements. Woodward actuators are designed to give stable operation with most oils with a viscosity (at operating temperature) between 50 and 3000 SUS (Saybolt Universal Seconds). At normal operating temperature, the viscosity should be between 100 and 300 SUS. Poor actuator response or instability may be an indication that the oil viscosity is outside this range.

Excessive component wear or seizure in an actuator indicates the possibility of:

1. Insufficient lubrication caused by:
 - An oil that flows slowly when it is cold especially during start-up
 - No oil in the actuator
2. Contaminated oil caused by:
 - Dirty oil containers
 - An actuator exposed to heating up and cooling down cycles, which creates condensation of water in the oil
3. Oil not suitable for the operating conditions caused by:
 - Changes in ambient temperature
 - An improper oil level which creates foamy, aerated oil

Operating an actuator continuously beyond the high limit temperature of the oil will result in oil oxidation. This is identified by varnish or sludge deposits on the actuator parts. To reduce oil oxidation, lower the actuator operating temperature with a heat exchanger or other means, or change to an oil that is more oxidation-resistant at the operating temperature.

**WARNING**

A loss of stable actuator control and possible turbine overspeed may result if the viscosity exceeds the 50 to 3000 SUS range. Loss of governor control can cause damage to equipment and personal injury or loss of life.

Specific oil viscosity recommendations are given on the Oil Chart (Table 2-1). Select a readily available good brand of oil, either mineral or synthetic, and continue using that same brand. Do NOT mix different classes of oils. Oil that meets the API (American Petroleum Institute) engine service classification in either the "5" group or the "C" group, starting with "SA" or "CA" through "SF" and "CD" is suitable for actuator service. Oils meeting performance requirements of the following specifications are also suitable: US MIL-L-2104A, MIL-L-2104B, MIL-L-2104C, MIL-L-46142, MIL-L-46152A, MIL-L-46152B, MIL-L-45199B.

Remove the breather/filler cap on the TG actuator. Fill the governor or actuator with 1.8 quarts (1.7 L) of oil to a level visible on the oil sight gauge. Additional oil is required if the governor uses an oil heat exchanger. Be sure that the oil level is visible on the oil sight gauge before starting the turbine. After the turbine is started and the TG actuator is at operating temperature, add oil if necessary.

For TG actuators which do not require a drive, but require a customer-supplied oil pressure source, see Figure 2-4 for oil line connections. The external oil pressure source must supply 1 to 4 gal/min (4 to 15 L/min) flow to regulate accumulator between 150 and 170 psi (1034 and 1172 kPa). Supply oil must be filtered to 25 μm (absolute). The TG actuator is fitted with a -6 filter fitting (70 μm absolute) and a -10 drain fitting.

Replace the actuator oil if it is contaminated. Also, change the oil if it is suspected of contributing to actuator instability. Drain the oil while it is still hot and agitated, and flush the actuator with a clean solvent having some lubricity (such as fuel oil or kerosene) before refilling with new oil. If drain time is insufficient for the solvent to completely drain or evaporate, flush the actuator with the same oil that will be used to refill. This will avoid dilution and possible contamination of the new oil. To avoid recontamination, the replacement oil should be free of dirt, water, and other foreign material. Use clean containers to store and transfer oil.

**WARNING**

Observe manufacturer's instructions or restrictions regarding the use of solvents. If no instructions are available, handle with care. Use cleaning solvent in a well ventilated area away from fires or sparks. Improper use of solvents can cause personal injury and/or property damage.

Oil that has been carefully selected to match the operating conditions and is compatible with actuator components should give long service between oil changes. For actuators operating under ideal conditions (minimum exposure to dust and water and within the temperature limits of the oil), oil changes can be extended.

If available, a regularly scheduled oil analysis is helpful in determining the frequency of oil changes. Any persistent or reoccurring oil problems should be referred to a qualified oil specialist for solution.

The recommended continuous operating temperature of the actuator is 140 to 200 °F (60 to 93 °C). Measure the temperature of the actuator on the outside lower part of the case. The actual oil temperature will be approximately 10 Fahrenheit degrees (6 Celsius degrees warmer).

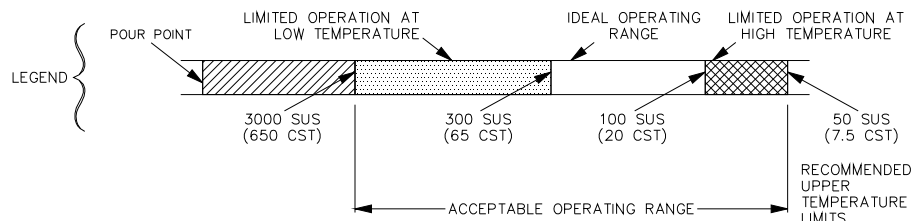
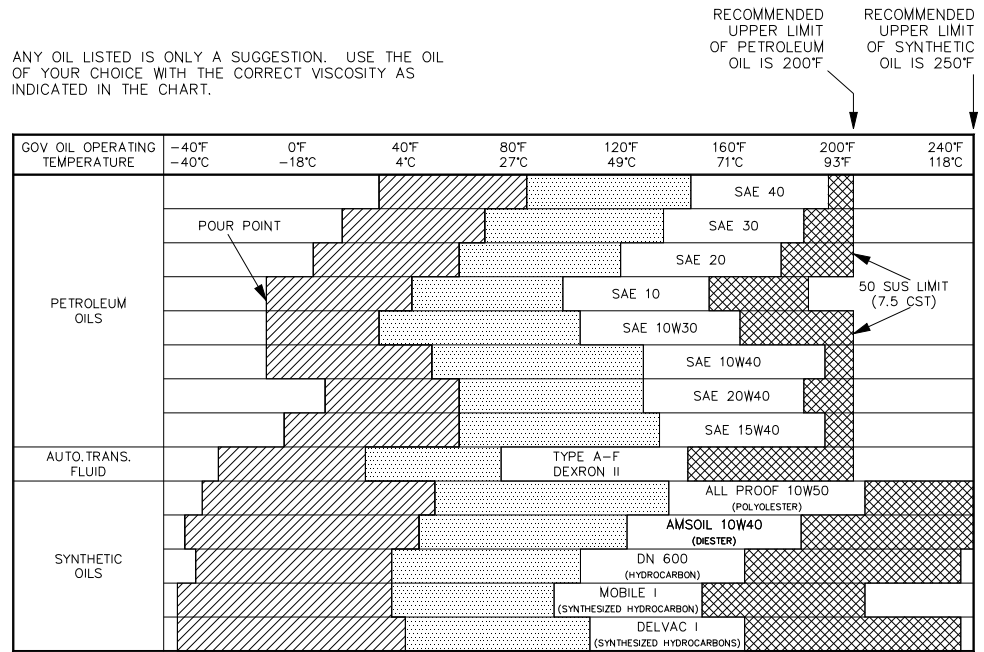

250-079H

Table 2-1. Oil Chart

VISCOSITY COMPARISONS				
CENTISTOKES (CST, CS, OR CTS)	SAYBOLT UNIVERSAL SECONDS (SUS) NOMINAL AT 100 DEGREES F	SAE MOTOR (APPROXIMATE)	SAE GEAR (APPROXIMATE)	ISO
15	80	5W		15
22	106	5W		22
32	151	10W	75	32
46	214	10	75	46
68	310	20	80	68
100	463	30	80	100
150	696	40	85	150
220	1020	50	90	220
320	1483	60	115	320
460	2133	70	140	460

250-087.
97-11-04 skw

Table 2-2. Viscosity Comparisons

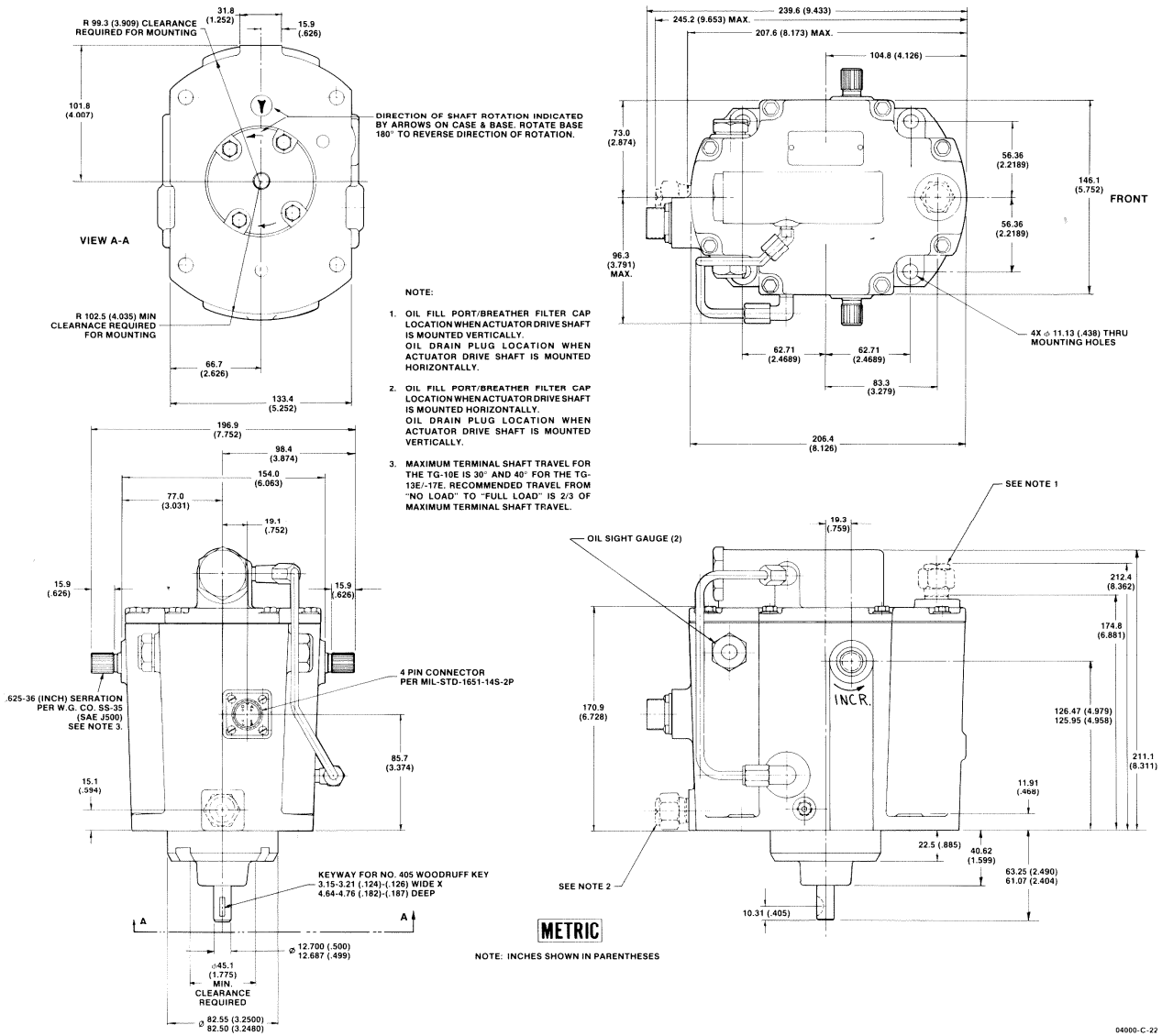

Terminals C and D must be jumpered in connecting plug. For reverse action, switch polarity at Terminals A and B.

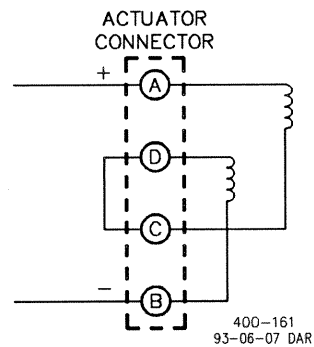
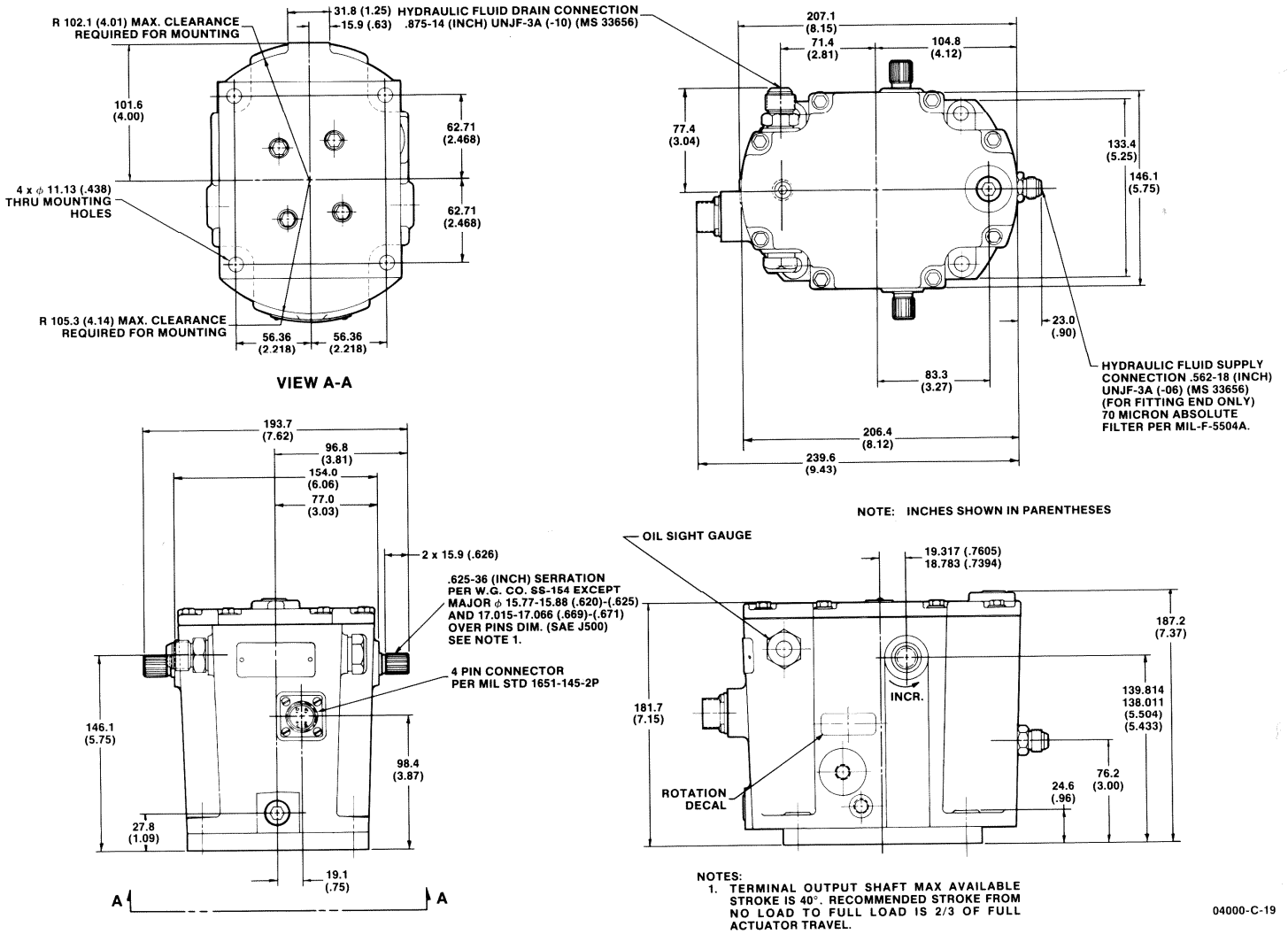

Figure 2-3. TG Actuator Outline Drawing



04000-C-19

Terminals C and D must be jumpered in connecting plug. For reverse action, switch polarity at Terminals A and B.

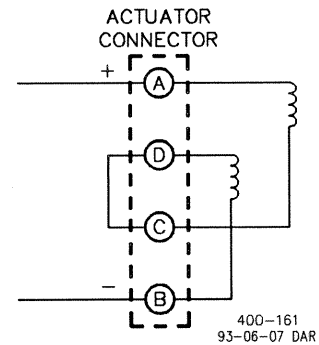
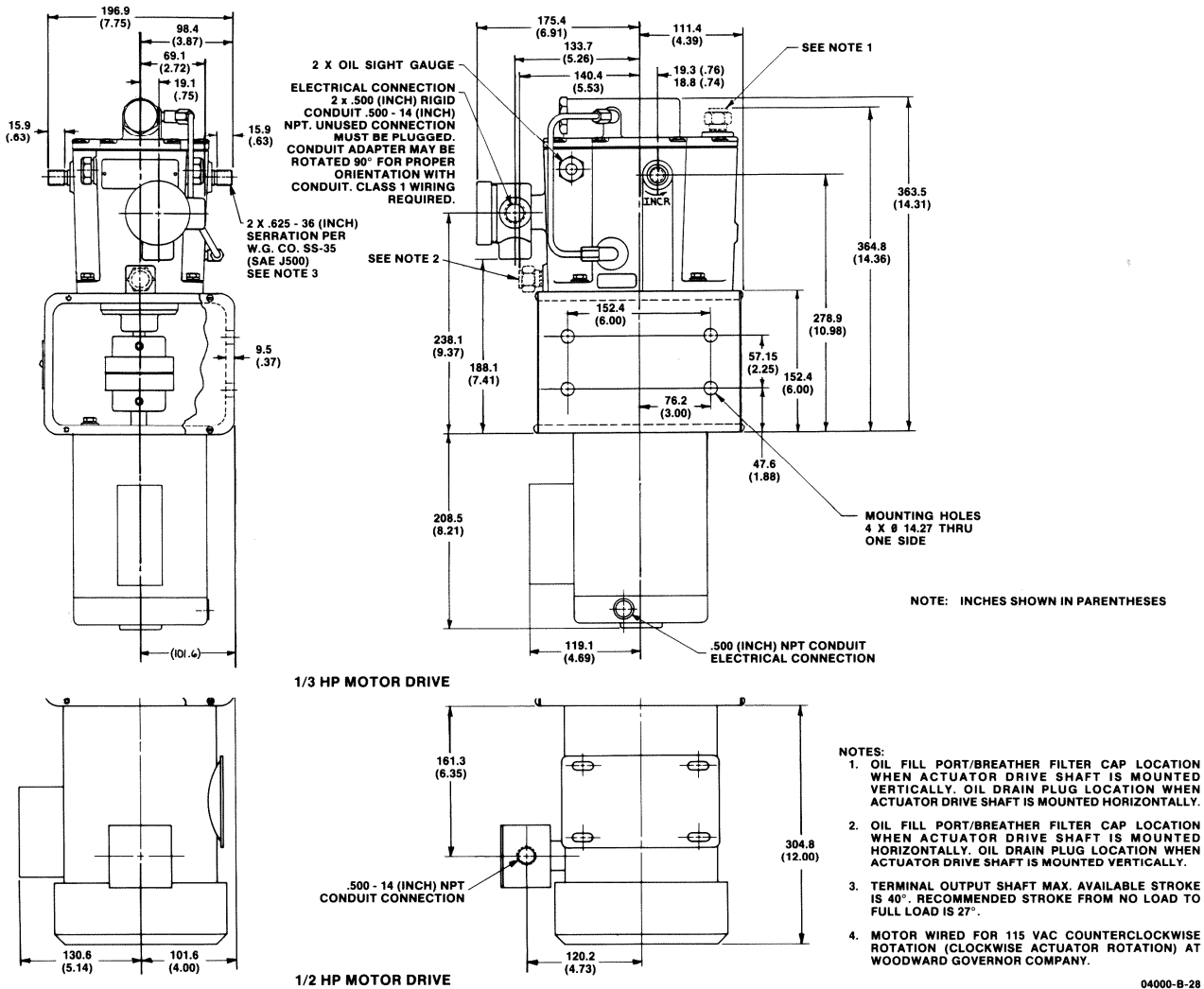
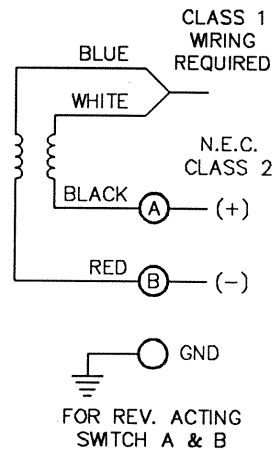

Figure 2-4. TG-13E/17E Outline Drawing (version that does not require a drive from the turbine)



Wire motors according to the diagram that comes with equipment. Rotation must be correct for actuator pump to function.



400-162
93-06-07 DAR

Figure 2-5. TG-13E/17E Outline Drawing (electric motor driven version with drives and adapters)

Chapter 3. Operation and Adjustments

Introduction

This chapter provides initial installation, adjustment, and operating instructions of the TG actuator.

WARNING

The engine, turbine, or other type of prime mover should be equipped with an overspeed shutdown device to protect against runaway or damage to the prime mover with possible personal injury, loss of life, or property damage.

The overspeed shutdown device must be totally independent of the prime mover control system. An overtemperature or overpressure shutdown device may also be needed for safety, as appropriate.

Initial Operation

Before initial operation of the TG equipped turbine, make sure that all previous installation steps have been correctly accomplished and that all linkages are secure and properly attached. See Chapter 2, Installation. Also, read all of this chapter.

WARNING

Be prepared to make an emergency shutdown when starting the engine, turbine, or other type of prime mover, to protect against runaway or overspeed with possible personal injury, loss of life, or property damage.

Follow the turbine manufacturer's instructions to start the turbine.

Normally, the only requirements for putting a new or overhauled TG actuator into service are to fill the actuator with oil (see Chapter 2, Oil Supply) and adjust the selected speed setting on the electronic speed control. Select a low-speed setting on the electronic control to give low turbine speed at initial start-up.

Maximum terminal shaft travel is 30 degrees for the TG-10E and 40 degrees for the TG-13E/-17E. Adjust the steam linkage so that terminal shaft travel from "NO LOAD" to "FULL LOAD" is 2/3 of maximum shaft travel (see Figure 2-1).

WARNING

Be sure to allow sufficient overtravel at each end of the terminal shaft so the actuator can shut down the turbine and also give maximum steam flow when required.

Open the steam valve slowly. Check the turbine speed and adjust as necessary to bring the turbine to rated speed.

Check the actuator and governor system for stable operation by manually disturbing the terminal shaft linkage or speed setting. Stability is satisfactory when the turbine returns to speed with only a slight overshoot or undershoot.

Cleaning the Filter Screens and The Pilot-Valve Plunger Orifice

The source of most troubles and failures with the TG actuator is from contamination of the filter screens and pilot-valve plunger orifice. Impurities can be introduced in the actuator with the oil, or form when the oil begins to break down (oxidize) or becomes sludgy. If this is the case, sluggish or erratic actuator operation (or loss of actuator control) can be corrected by using the following procedure to clean the filter screen and the pilot-valve plunger orifice.

Cleaning the Filter Screens

1. SHUT DOWN THE TURBINE, following the turbine manufacturer's instructions.
2. Drain the oil from the actuator through the oil drain plug (see Figure 1-1).
3. Use a 1-3/8 inch (35 mm) wrench and remove the oil filter hex nut. The filter is attached to the nut and is pulled out as the nut is removed.
4. Wash the filter ultrasonically or by agitation in fuel oil. Dry the filter with a jet of clean, dry, compressed air.
5. Reinstall the filter and torque the filter hex nut down.
6. Fill the actuator with clean, fresh oil, (see Chapter 2, Oil Supply).

Cleaning the Pilot-Valve Plunger Orifice

1. SHUT DOWN THE TURBINE, following the turbine manufacturer's instructions.
2. Drain the oil from the actuator through the oil drain plug (see Figure 1-1).
3. Remove the actuator cover and supply tube for cover filter.
4. Remove the two screws holding the transducer clamp bracket (brass bracket). Do NOT change the settings of the level adjusting screw or the range adjustment slider (see Figure 3-1 for identification of parts).
5. Turn the clamp bracket slightly to one side to release the restoring lever from the terminal lever.
6. Remove the restoring spring.

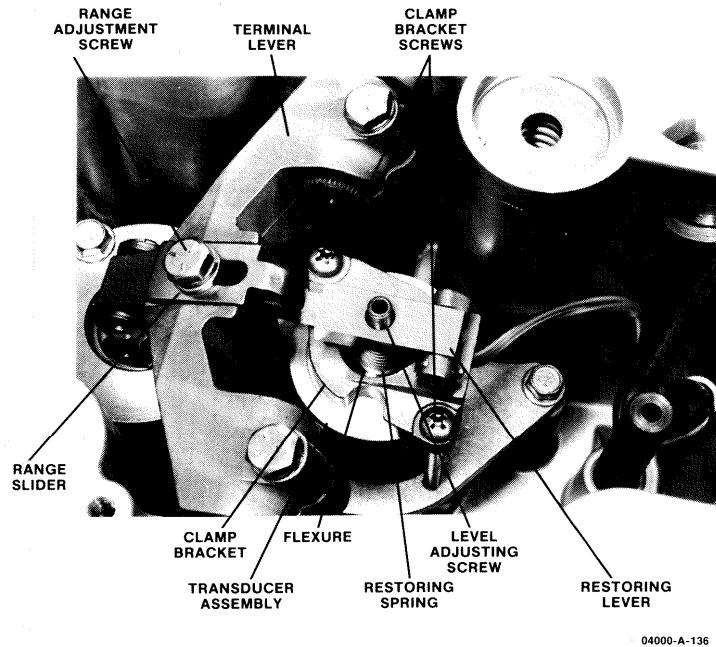

Figure 3-1. TG Actuator with Cover Removed

7. Lift off the transducer assembly and carefully move it to the side.
8. Pull out the pilot-valve plunger and its bushing.
9. Remove the snap ring from the pilot valve-bushing. Carefully pull out the pilot-valve plunger and bushing. Do not bang the parts together.
10. Immerse the pilot-valve plunger and bushing in diesel fuel oil or approved cleaning solvent and wash ultrasonically or by agitation. Use a non-metallic brush or jet of compressed air to clean slots, bushing filter screen, holes, and pilot-valve plunger orifice.
11. Reinsert the pilot-valve plunger into the bushing. Make sure that the pilot-valve plunger slides freely of its own weight while shaking the bushing. If not, disassemble and check for nicks or scratches on the plunger lands.
12. Reinstall the transducer assembly in reverse order from disassembly, making certain that all parts are properly seated.
13. Torque the two screws evenly to 25 lb-in (2.8 N·m) while holding the transducer clamp bracket.

NOTICE

Uneven torque, misalignment of spacer rings, or improperly seated rings can cause a large calibration shift.

14. Fasten the cover to the actuator with eight cover screws. Torque the screws to 100 lb-in (11.3 N·m). Reinstall the filter supply tube.
15. Fill the actuator with clean, fresh oil (see Chapter 2, Oil Supply).

16. Recalibrate the TG actuator after completing the above procedure. See below: Procedure with Actuator on the Turbine OR Calibration Procedure with Actuator on a Test Stand.

Calibration Procedure

There are several conditions which require a recalibration of the TG actuator:

- When the installation is changed from vertical to horizontal, or vice versa.
- After performing a transducer assembly tightness check, disassembly, and rework.
- After cleaning the pilot-valve orifice plunger.
- Any time a calibration shift is suspected.

Calibration Procedure with Actuator on the Turbine

1. CLOSE THE HAND-THROTTLE STEAM VALVE, following the turbine manufacturer's instructions.



When operating the hand-throttle, the system is not under actuator control, and extreme caution must be taken to prevent overspeed. Do not attempt if the overspeed device is not functioning.

2. Disconnect the actuator from the steam control valve linkage.
3. Remove the actuator electrical connection.
4. Manually rotate the actuator terminal shaft to its full minimum position and mark that position with a reference mark.



Be prepared to make an emergency shutdown when starting the engine, turbine, or other type of prime mover, to protect against runaway or overspeed with possible personal injury, loss of life, or property damage.

5. Following the turbine manufacturer's instructions, carefully start the turbine manually using the hand-throttle steam valve, and set the speed at the following speed setting:
 - 1500 rpm on actuators marked 2400 rpm
 - 2400 rpm on actuators marked 4000 rpm
 - 4000 rpm on actuators marked 6000 rpm
6. Apply a 0 to 200 mA power source to pins A and B of the connector to check the level adjustment on the actuator (see Figure 3-2).

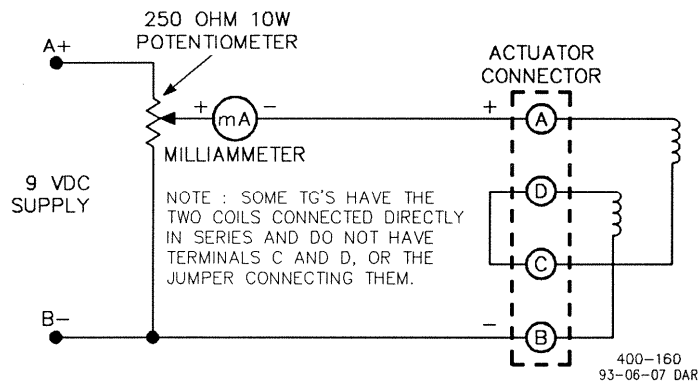

Figure 3-2. Wiring Diagram for Actuator Calibration Circuit

7. With no current applied, make sure that there is no travel of the terminal shaft from the minimum position.
8. A recalibration is required if any of the following conditions exists:
 - (1) With 20 mA current applied, if less than 1-degree movement or more than 3-degree movement is seen from minimum position
 - (2) With 160 mA current applied, if less than 37-degree movement or more than 39-degree movement is seen from minimum position (27 to 29 degrees for TG-10E)
 - (3) If the terminal shaft does not rotate smoothly from one position to another, or if it does not take the same position for the same potentiometer setting when rotated from the increase or decrease position
9. SHUT DOWN THE TURBINE following the turbine manufacturer's instructions, remove the actuator cover and supply tube for actuator cover. (If the actuator is mounted horizontally, first drain the actuator oil through the oil drain plug.)
10. If condition (1) or (2) in Step 8 above exists, skip Step 11 below and go to Step 12 to recalibrate the actuator.
11. If condition (3) in Step 8 above exists, the transducer assembly must be disassembled before recalibrating the actuator to make sure that there is no binding of the feedback lever, spring, transducer assembly, or pilot-valve plunger.

Disassemble the transducer assembly as follows:

- (1) Remove the two screws holding the transducer clamp bracket (brass bracket). Do NOT change the settings of the level adjusting screw or the range adjustment slider (see Figure 3-1 for identification of parts).
- (2) Turn the clamp bracket slightly to one side to release the restoring lever from the terminal lever.
- (3) Remove the restoring spring.
- (4) Lift off the transducer assembly and carefully move it to the side.
- (5) Pull out the pilot-valve plunger and its bushing.
- (6) Remove the snap ring from the pilot-valve bushing and pull out the pilot-valve.
- (7) Immerse the pilot-valve plunger and bushing in diesel fuel oil or approved cleaning solvent and wash ultrasonically or by agitation. Use a non-metallic brush or jet of compressed air to clean slots, bushing filter screen, holes, and pilot-valve plunger orifice.

- (8) Make sure that the pilot-valve plunger slides freely of its own weight while shaking the bushing, after reassembling the pilot-valve plunger into the bushing. If not, disassemble and check for nicks or scratches on plunger lands.
- (9) Reinstall the transducer assembly in reverse order from disassembly, making certain that all parts are properly seated.
- (10) Torque the two screws holding the transducer clamp bracket evenly to 25 lb-in (2.8 N·m).

NOTICE

Uneven torque, misalignment of spacer rings, or improperly seated rings can cause a large calibration shift.

- (11) If actuator oil was drained in Step 9, fasten the cover with eight cover screws and torque screws to 100 lb-in (11.3 N·m). Reinstall the filter supply tube and refill actuator with clean, fresh oil.
 - (12) Proceed now to recalibrate the TG actuator as shown in the next step.
12. If no movement of the actuator terminal shaft was seen after starting the turbine in Step 5 above, turn the level adjusting screw 1/8 turn clockwise with a 1/8 inch (3 mm) Allen wrench. The level adjusting screw can be found above the transducer (see Figure 3-1).
- If too much movement of the actuator terminal shaft was seen after starting the turbine, turn the level adjusting screw 1/8 turn counterclockwise.
13. Repeat Step 12 until 1 to 3 degrees of terminal shaft movement is seen when the turbine is started and 20 mA is applied.
14. Check the range adjustment on the actuator. With 20 mA current applied, terminal shaft travel must be 1 to 3 degrees from minimum position. With 160 mA current applied, terminal shaft travel must be 37 to 39 degrees from minimum position (27 to 29 degrees on the TG-10E).
15. If terminal shaft travel is incorrect, adjust the range adjustment (see Figure 3-1). Moving the range lever slider away from the center of the actuator decreases the range, and moving it towards the center increases the range.
16. Repeat Steps 12 and 13 (level adjustment) if the range slider has been moved in Step 15 above (range adjustment).
17. Rotate the test circuit potentiometer to various positions while looking at the movement of the actuator terminal shaft. The terminal shaft must rotate smoothly from one position to another. It also must take the same position for the same potentiometer setting when rotated from the increase or decrease position.
18. Reconnect the actuator to the steam control valve with the control linkage. Adjust the linkage so that there is approximately 5 degrees of terminal shaft overtravel from minimum actuator position with the steam control valve at its tightly closed position.
19. Reconnect the actuator electrical connector.
20. Fasten the cover with eight cover screws and torque screws to 100 lb-in (11.3 N·m). Reinstall the filter supply tube and refill actuator with clean, fresh oil.

This completes the recalibration of the TG actuator on the turbine.

Calibration Procedure with Actuator on a Test Stand

If a TG actuator requiring a customer-supplied hydraulic pressure source is to be recalibrated, in addition to using the procedure described below, be sure to meet the following requirements:

- Supply the filter fitting with the oil filtered to 10 to 30 μm (nominal). This ensures that the 40 μm filter fitting is not contaminated.
- The drain flow must be approximately 1 to 2 gal/min (4 to 8 L/min) to ensure that the accumulator is bypassing. The oil supply pressure must be 160 psi (1103 kPa) minimum.

Use the following procedure to calibrate the TG actuator:

1. Mount the actuator vertically on the test stand.
2. Remove the cover and plug the oil line to the actuator filter.
3. Connect a test circuit to pins A and B on the pin connector to the actuator. The test circuit is shown in Figure 3-2.
4. With no current applied, make sure that there is no travel of the terminal shaft from the minimum position.
5. A recalibration is required if any one of the following conditions exists:
 - (1) With 20 mA current applied, if less than 1-degree movement or more than 3-degree movement is seen from minimum position
 - (2) With 160 mA current applied, if less than 37-degree movement or more than 39-degree movement is seen from minimum position (27 to 29 degrees for TG-10E)
 - (3) If the terminal shaft does not rotate smoothly from one position to another, or if it does not take the same position for the same potentiometer setting when rotated from the increase or decrease position.
6. If none of the conditions listed in Step 5 above exists, a recalibration is not required. Drain actuator oil; fasten the cover with eight cover screws and torque screws to 100 lb-in (11.3 N·m). Reinstall the filter supply tube.
7. If condition (1) or (2) in Step 5 above exists, skip Step 8 and go to Step 9 to recalibrate the actuator.
8. If condition (3) in Step 5 above exists, the transducer assembly must be disassembled before recalibrating the actuator to make sure that there is no binding of the feedback lever, spring, transducer assembly, or pilot-valve plunger.

Disassemble and reassemble the transducer assembly as explained previously in Step 11 of the previous section.
9. Install and secure a protractor over the terminal shaft. Use the terminal shaft as an indicator and rotate the output shaft over its full range of travel. Mark the minimum and maximum shaft positions on the protractor. The total terminal shaft travel must be 40 degrees.
10. Use SAE 10 oil at 60 degrees F to 180 F. Fill actuator to within 2 inches of top. Always use an oil filter with 140 μm maximum rating on the accumulator bypass during recalibration.

11. Drive (rotate) the actuator drive shaft in the proper direction of rotation (clockwise or counterclockwise) according to the actuator specification sheet, and drive the actuator at the following speed setting:
1500 rpm on actuators marked 2400 rpm
2400 rpm on actuators marked 4000 rpm
4000 rpm on actuators marked 6000 rpm
12. All calibration is done open loop. Set the power supply to 20 mA. Turn the level adjusting screw counterclockwise (see Figure 3-1) with a 1/8 inch (3 mm) Allen wrench, until the terminal shaft moves from 1 to 3 degrees from the minimum position.
13. Set the power supply to 160 mA. The terminal shaft must move from 37 to 39 degrees from the minimum position. Adjust the range adjustment (see Figure 3-1) if terminal shaft travel is incorrect. Moving the range slider away from the center of the actuator decreases the range, and moving it toward the center increases the range (27 to 29 degrees for the TG-10E.)

Repeat Steps 12 and 13 until the correct travel range is obtained.

14. If the actuator is to be horizontally mounted, the level adjustment will shift +6 degrees towards the minimum position. Set the power supply to 20 mA and turn the level adjustment screw clockwise until the terminal shaft moves 7 to 8 degrees from the minimum position. The actuator is now correctly adjusted for horizontal installation.
15. Rotate the test circuit potentiometer to various positions while looking at the movement of the actuator terminal shaft. The terminal shaft must rotate smoothly from one position to another. It also must take the same position for the same potentiometer setting when rotated from the increase or decrease position.
16. Fasten the cover with eight cover screws and torque the screws to 100 lb-in (11.3 N·m). Reinstall the filter supply tube.

This completes the calibration of the TG actuator on the test stand.

Chapter 4.

Principles of Operation

Introduction

This chapter describes the operation of the TG actuator. The schematic drawing (Figure 4-1) illustrates the working relationship of the various parts shown in the relative position assumed during normal operation.

Internally, the TG actuator consists of the following basic components:

- Oil pump
- Oil accumulator
- Oil filter
- Transducer with flapper
- Pilot-valve plunger
- Power piston
- terminal lever with shaft

In Figure 4-1, the connecting oil passages between the components are simplified for ease in visualizing the system.

Component Operation

A brief description of the operation of the components will facilitate understanding the operation of the actuator.

The oil pump (14) is a Gerotor-type pump which provides oil pressure for the actuator. The oil pump is driven by the actuator drive shaft, which in turn is driven by the turbine or by an optional remote drive. The pump draws oil from the sump and distributes it through the oil passages within the case. The accumulator (30) maintains the operating pressure at rated speed (150 psi/1034 kPa for the TG-10E/TG-13E or 200 psi/1379 kPa for the TG-17E). Excess pressure compresses the accumulator springs, and oil flows through the accumulator bypass (17) to the filter (26).

An increase or a decrease in current from the governor moves the pilot-valve plunger downward or upward. Plunger movement opens the control port and releases oil either to sump or to the under side of the power piston. During power piston movement, the accumulator supplements the system oil supply with its stored volume of high pressure oil and helps maintain the full work capacity of the actuator.

The power piston (6) rotates the actuator terminal shaft (2) to the increase- or decrease-steam position. The top end of the power piston (6) is connected to the actuator terminal shaft (2) through a terminal lever (4) and link assembly (5). The power piston is a differential type with oil pressure on both sides of the piston. The underside of the power piston has a larger area than the upper side of the piston. Therefore, if the oil pressure is the same on both the upper and underside of the piston, the piston moves up to rotate the actuator terminal shaft in the increase steam direction. The piston moves down only when oil under the piston is released to sump. Constant oil pressure is applied to the upper side of the power piston, always loading it in the decrease-steam direction. Oil to and from the bottom of the power piston is regulated by the pilot-valve plunger system.

The pilot-valve plunger system includes the nozzle/pilot-valve plunger (20) and the pilot-valve bushing (7). When the nozzle/pilot-valve plunger (20) is lowered, high pressure oil flows under the power piston (6), raising it. When the nozzle/pilot-valve plunger is raised, oil is released to sump from under the power piston (6), lowering it. When the nozzle/pilot-valve plunger (20) is in its "centered" position, the control land covers the control port as shown in the schematic (Figure 4-1), and there is no movement of the power piston and no movement of the actuator terminal shaft (2).

The movement of the pilot-valve plunger (20) is controlled hydraulically by varying the oil flow from the nozzle of the pilot-valve plunger with a flapper (11). The upward and downward movement of the flapper is controlled by the transducer (12). As the flapper (11) moves closer to the nozzle, the restriction to oil flow at the nozzle is increased. As a result, the oil pressure acting on the upper side of the differential power land (19) starts increasing. Since the area is greater on the upper side than on the lower side of the differential power land (19), the now greater force exerted on the upper side of the power land causes the pilot-valve plunger (20) to move downward. As it moves downward, the pilot-valve plunger control land uncovers the control port in the pilot-valve plunger bushing (7). Pressure oil is now directed to the underside of the power piston (6), causing it to move upward, rotating the terminal shaft (2) in the increase-steam direction. As the terminal shaft (2) rotates in the increase-steam direction, the restoring lever (13) moves up, decreasing the restoring spring (25) force. When the terminal shaft (2) has rotated far enough so that the decrease in restoring spring force equals the increase in magnetic force in the solenoid coils (23), the pilot-valve plunger is re-centered.

The opposite sequence of movements takes place when the transducer (12) causes the flapper (11) to move away from the nozzle (20).

As the flapper (11) moves away from the nozzle (20), the restriction to oil flow at the nozzle decreases. As a result, the oil pressure acting on the upper side of the differential power land (19) starts decreasing. The now greater oil pressure acting on the lower side of the differential power land (19), causes the pilot-valve plunger (20) to move upward. As it moves upward, the pilot-valve plunger control land uncovers the control port in the pilot-valve plunger bushing (7). Oil from the underside of the power piston (6) is now released to sump, and pressure oil acting on the upper side of the power piston moves the power piston downward, rotating the terminal shaft (2) in the decrease-steam direction. As the terminal shaft rotates in the decrease-steam direction, it causes the restoring lever (13) to move down, increasing the restoring spring (25) force. When the terminal shaft has rotated far enough so that the increase in restoring spring force equals the decrease in downward magnetic force in the solenoid coils (23), the pilot-valve plunger is re-centered.

During operation, the pilot-valve plunger (20) and the transducer (12) act as if they were a single piece, acting together, as the gap between nozzle and flapper remains nearly constant. The upward and downward movement of the flapper is controlled by the transducer (12).

The transducer (12) converts the electrical signal given by the electronic control to a proportional downward movement of the permanent magnet (22) and its attached flapper (11). Please refer to the applicable Woodward manual for information regarding the electronic speed control selected.

Opposing the downward magnetic force exerted by the transducer (12) is a resultant spring force from the load spring (24). The load spring (24) sits on top of the case in which the transducer (12) is located, and exerts a constant upward force on the magnet (22) and its attached flapper (11). The restoring spring (25), weaker than the load spring (24), exerts a downward force on the magnet (22) and its attached flapper (11). The amount of downward force exerted by the restoring spring (25) depends upon the position of the restoring lever (13).

When the power piston (6) which is attached to the terminal lever (4) moves up, the terminal lever (4) and the restoring lever (13) also move up, decreasing load on the restoring spring (25). When the power piston (6) moves down, the terminal lever (4) and the restoring lever (13) move down, increasing load on the restoring spring (25).

With a constant current, the resultant spring force and the constantly opposing magnetic force always balance, and the pilot-valve plunger is "centered." The control land of the pilot-valve plunger exactly covers the control port in the pilot-valve bushing, and no oil flows to or from the power piston.

Operation of the TG Actuator

General Information

Refer to Figure 4-1 to better understand the operation of the TG actuator.

The description that follows discusses the TG actuator operation. It must be remembered that the actuator only responds to a change of dc voltage coming to the transducer. The load or speed sensing must come from an electronic control. The description that follows is based on load changes. The integrating control senses the load change and proportionally varies the dc voltage going to the actuator. (Changes in the system control speed setting produce the same actuator movements as do changes in load on the turbine.)

Decrease in Load or Speed Setting

Assume that the turbine is running on-speed under steady-state conditions. The control voltage to the actuator is therefore constant. The pilot-valve plunger (20) is centered over the control port of the pilot-valve bushing (7) and the control land stops the flow of the pressure oil through the bushing control port. There is no movement of the power piston (6) and no movement of the actuator terminal shaft (2).

A decrease in load (or speed setting) causes a decrease in control voltage to the transducer (12). This in turn causes a decrease in the magnetic force tending to raise the flapper (11). For the reasons explained above, the pilot-valve plunger (20) always follows the flapper and the pilot-valve plunger moves upward, above center, uncovering the pilot-valve bushing (7) port. Oil escapes from under the power piston (6), causing the power piston to move downward and the terminal shaft (2) to rotate in the decrease-steam direction. As the terminal shaft rotates in the decrease-steam direction, it causes the restoring lever (13) to move down, increasing the restoring spring force (25). The terminal shaft rotates until the increase in restoring spring (25) force equals the decrease in downward magnetic force in the transducer (12). Then the pilot-valve plunger (20) is re-centered.

The control port in the pilot-valve bushing (7) is covered by the land on the pilot-valve plunger (20). This stops the power piston (6) and the actuator terminal shaft (2) in the new position needed to run the turbine at the decreased load or decreased-speed setting.

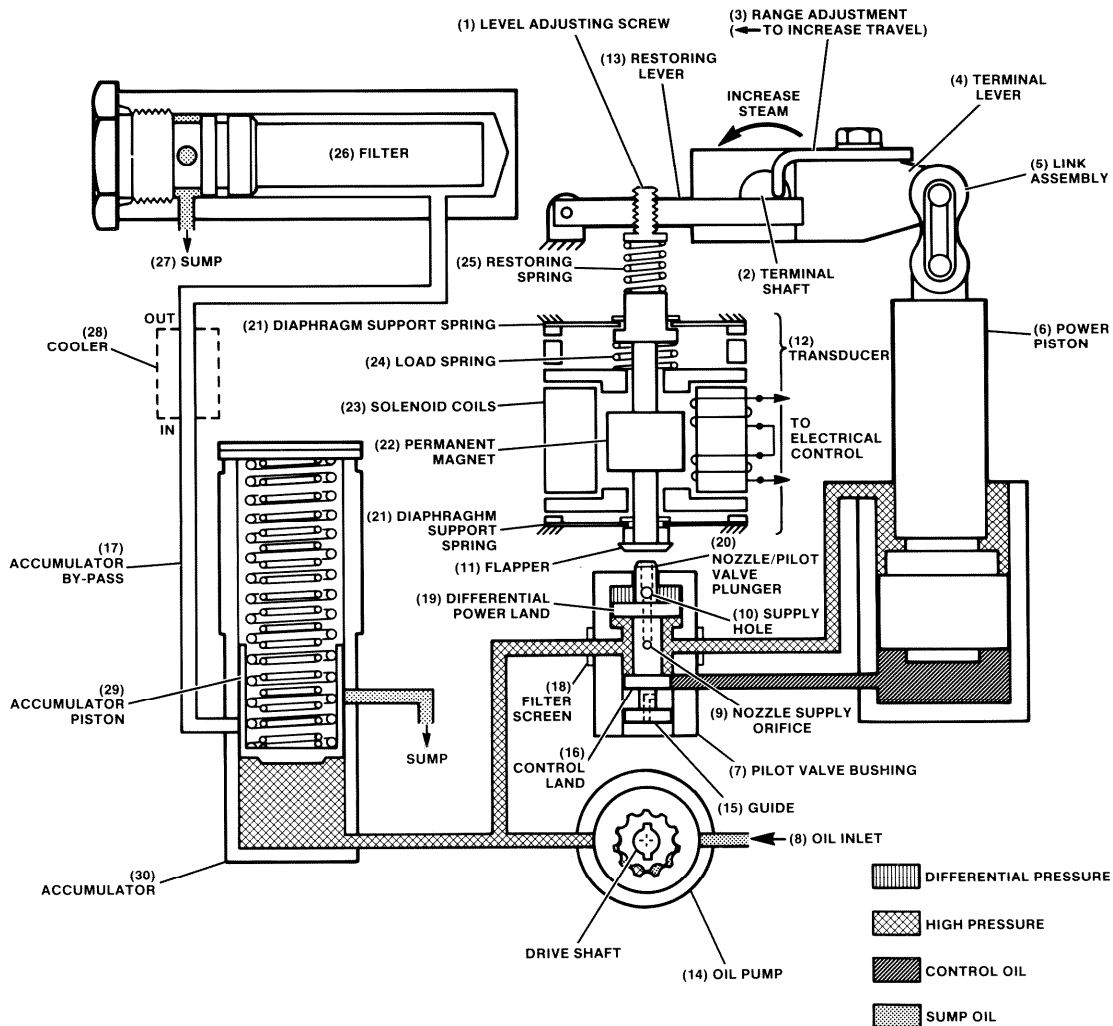

04000-B-5

Figure 4-1. TG Actuator Schematic Diagram

Increase in Load or Speed Setting

Assume that the turbine is running on-speed under steady-state conditions. The control voltage to the actuator is therefore constant. The pilot-valve plunger (20) is centered over the control port of the pilot-valve bushing (7) and the control land stops the flow of pressure oil through the bushing control port. There is no movement of the power piston (6) and no movement of the actuator terminal shaft (2).

An increase in load (or speed setting) causes an increase in control voltage to the transducer (12). This in turn causes an increase in the magnetic force tending to lower the flapper (11) and the hydraulically controlled pilot-valve plunger (20). As it moves downward, the pilot-valve plunger control land uncovers the control port in the pilot-valve bushing (7). Pressure oil is now directed to the underside of the differential power piston (6), causing it to move upward, and to rotate the terminal shaft (2) in the increase-steam direction. As the terminal shaft (2) rotates in the increase-steam direction, the restoring lever (13) moves up, decreasing the restoring spring (25) force. The terminal shaft (2) rotates until the decrease in restoring spring (25) force equals the increase in downward magnetic force in the transducer (12) and the pilot-valve plunger is re-centered.

The control port in the pilot-valve bushing (7) is covered by the land on the pilot-valve plunger (20). This stops the power piston (6) and the actuator terminal shaft (2) in the new increase-steam position. The actuator has now reached the new position to run the turbine at the selected speed setting with the increased load or increased speed setting.

Chapter 5.

Troubleshooting

Introduction

This chapter provides instructions for troubleshooting.

Poor governing may be due to faulty actuator performance, or it may be due to the actuator attempting to correct for faulty operation of the turbine or the equipment driven. The effect of any auxiliary equipment on the overall control required of the actuator must be considered. Some actuator troubles can also be related to control signal problems. Please refer to the appropriate manual for troubleshooting information on the Woodward electronic control used with the TG actuator.

WARNING

Be prepared to make an emergency shutdown when starting the engine, turbine, or other type of prime mover, to protect against runaway or overspeed with possible personal injury, loss of life, or property damage.

Visual Inspection

Actuator troubles are usually revealed in speed variations of the turbine, but it does not follow that all speed variations are caused by the actuator. When improper speed variations appear, the following procedure should be performed:

1. Check the load to be sure the speed changes are not the result of load changes beyond the capacity of the turbine.
2. Check the control valve for proper operation.
3. Check the linkage between the actuator and the steam valve. There must be no binding, no lost motion, and/or no inadequate travel.
4. Make sure that the oil level is in the oil sight glass at operating temperature. Remove the breather/filler cap and add oil if necessary (see Chapter 2, Oil Supply).
5. SHUT DOWN THE TURBINE.
6. While the turbine is shut down, disconnect the control linkage between the actuator and the control valve or fuel rack.

NOTICE

During this test, the actuator is disconnected from the turbine.

7. Disconnect the leads from the actuator terminals. Hook up a circuit to the actuator, as shown in Figure 5-1.

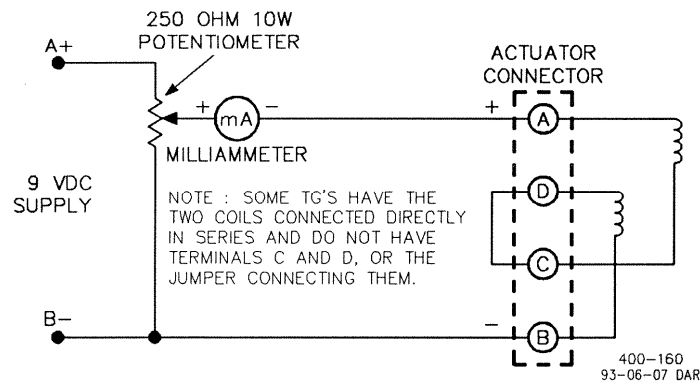

Figure 5-1. Actuator Test Circuit

8. If necessary to provide drive or oil pressure to the actuator—depending on the type of drive and source of oil pressure used on the particular TG—start the turbine UNDER MANUAL CONTROL, following the turbine manufacturer's instructions.
9. Control prime mover speed MANUALLY and bring turbine speed to a SLOW SPEED to develop actuator working pressure.
10. Slowly rotate the potentiometer through its range and observe the actuator's shaft movement.

The terminal shaft must move through its range of travel as the potentiometer is rotated and must take the same position each time for a given potentiometer setting.

If the terminal shaft positions or operates erratically, the problem is in the actuator.

11. Check the removable cover filter element for possible clogging if actuator control is sluggish or just stops. The cover filter filters all internal oil. Clean and back-flush the filter in fuel oil or kerosene and reinstall. Remove this filter only after the turbine has stopped rotating and the oil has been drained from the actuator.

If an external oil supply is used, there is no cover filter element. Instead, the actuator is fitted with a -6 filter fitting (70 μ m absolute) and a -10 drain fitting. Check the filter for possible clogging, clean and back-flush the filter with fuel oil or kerosene, and re-install.

The TG actuator is also fitted with a filter screen (18) as a secondary filter, which is part of the pilot-valve bushing. It is used to protect the nozzle supply orifice from possible clogging. Checking the secondary filter requires partial disassembly and recalibration of the actuator. See Chapter 3, Procedure for Cleaning the Filter Screens and the Pilot-Valve Plunger Orifice, as well as Chapter 3, Calibration Procedure.

Dirty oil causes most actuator troubles. Use new, clean, filtered oil. Oil containers must be perfectly clean. Oil contaminated with water breaks down rapidly, causing foaming and corrosion of internal parts. This usually results in sluggish, erratic, or complete loss of actuator control.

12. Check electronic control output for proper voltage. Refer to the applicable Woodward manual for troubleshooting the electronic control.

Use the troubleshooting chart (Table 5-1) on the next page to determine the probable cause of faulty operation and to correct these troubles.

WARNING

The engine, turbine, or other type of prime mover should be equipped with an overspeed shutdown device to protect against runaway or damage to the prime mover with possible personal injury, loss of life, or property damage.

The overspeed shutdown device must be totally independent of the prime mover control system. An overtemperature or overpressure shutdown device may also be needed for safety, as appropriate.

Table 5-1. TG Actuator Troubleshooting

Symptoms	Cause	Correction
1. The turbine hunts or surges.	A. Low oil level	Add oil to a level visible in the oil sight glass.
	B. Dirty oil	Clean and back-flush cover filter in fuel oil or kerosene. Change oil.
	C. Binding terminal shaft linkage	Align linkage as necessary.
2. The actuator has difficulty in accepting load, or is unstable as evidenced by a slow and unsteady oscillation especially after a load change.	A. Insufficient use of terminal shaft travel	Check linkage and readjust. Recommended travel is 2/3 of maximum actuator shaft travel from no load to full load.
	B. High steam valve gain	Check that steam valve is not too large or oversize for the particular application.
	C. Dirt in actuator	Drain, flush, and refill with fresh oil. Clean cover filter.
3. The turbine cannot obtain rated speed.	A. Incorrect terminal shaft linkage travel	Check linkage. Recommended travel is 2/3 of maximum actuator shaft travel from no load to full load.
4. The actuator does not start or control.	A. Wrong actuator drive rotation	Check turbine drive to the actuator. Reverse pump parts for opposite direction of rotation. See Chapter 2, Installation.
	B. Key not properly installed or missing; drive shaft is not engaged	Remove actuator and properly install a No. 5 Woodruff key into actuator drive.
	C. Incorrect control voltage	Check electric control output for proper voltage, and adjust. Check polarity.
5. Actuator does not provide rated work capacity. Low oil pressure at low speeds.	A. Actuator oil too hot; oil viscosity too low	Use higher viscosity oil and/or an oil cooler. See Chapter 2, Oil Supply.
	B. Improper speed range actuator	Check actuator part number to verify proper matching with turbine speed.
6. Erratic actuator control; actuator may stick at maximum fuel.	A. Transducer assembly is not tight	See Woodward Service Bulletin number 50055 for transducer disassembly and rework.

Chapter 6. Replacement Parts

When ordering replacement parts, include the following information:

- Governor serial number and part number shown on the nameplate
- Manual number (this is Manual 04045)
- Part reference number and part name from parts list

Ref.	Part Description	Quantity	Ref.	Part Description.....	Quantity
04045-1	Breather, Filler Cap.....	1	04045-42	Sleeve, Collar	1
04045-2	Screw, .250-20" x .750".....	12	04045-43	Seal, Oil.....	1
04045-3	Cotter Pin.....	1	04045-44	Bearing, Ball.....	1
04045-4	Drilled Pin	1	04045-45	Ring, Int. Bowed, Retaining.....	1
04045-5	Restoring Lever Assembly.....	1	04045-46	Tube, TG Accumulator Bypass.....	1
04045-6	Screw, 10-32 x 2.5", Pan Hd.....	2	04045-47	Plug, 1/2 Inch Pipe, Socket Hd.....	1
04045-7	Screw, .250-20" x 1.000".....	3	04045-48	Screw	4
04045-8	Lock Washer, .250" Spring Lock.....	3	04045-49	Washer, No. 6 Split Lock.....	5
04045-9	Flat Washer, .250" ID.....	3	04045-50	Receptacle Retainer Plat.....	1
04045-10	Range Slider	1	04045-51	Receptacle	1
04045-11	Terminal Lever.....	1	04045-52	Screw, NO. 2 x .125, Drive	2
04045-12	Servo Piston Housing	1	04045-53	Nameplate, TG-13E	1
04045-13	Connecting Link Assembly.....	1	04045-54	Elbow, 45°, 1/8 Pipe, 1/4 Ferulok Tube	1
04045-14	Servo Piston	1	04045-55	Shaft, TG Terminal	2
04045-15	Magnet Assembly	1	04045-56	Oil Seal.....	2
04045-16	Spacer, Lower Transducer.....	1	04045-57	Needle Bearing.....	2
04045-17	Not used		04045-58	Case, TGE.....	1
04045-18	Not used		04045-59	Transducer Assembly.....	1
04045-19	Spacer, Diaphragm.....	1	04045-60	Retainer, Top Coil	1
04045-20	Diaphragm, Magnet Centering.....	2	04045-61	Support, Diaphragm	1
04045-21	Pilot, Clamping.....	1	04045-62	Spacer, Upper Transducer	1
04045-22	Plunger, Transducer	1	04045-63	Spring, TG-10E Return.....	1
04045-23	Pilot, Transducer.....	1	04045-64	Not Used	
04045-24	Ring, Int. Retaining, .482 Free Dia.....	1	04045-65	Not Used	
04045-25	Bushing, Power Servo	1	04045-66	Seat, Restoring Spring	1
04045-26	Plunger Assy, Dog Valve Nozzle	1	04045-67	Screw, 6-32 x .750 Inch, Soc Hd Cap ..	1
04045-27	Washer, Spring.....	1	04045-68	Bracket, Transducer Clamp.....	1
04045-28	Filter Screen	1	04045-69	Washer, Split Lock, No. 10.....	2
04045-29	Bushing Assy, Dog Valve, Includes Screen	1	04045-70	Spring, Feedback	1
04045-30	Plate, TGE Transducer Mounting	1	04045-71	Seat, Adj. Spring	1
04045-31	Ring, Ext. Retaining, Bowed, .461 Dia..	1	04045-72	TG-10E Cover	1
04045-32	Ring, Ext. Retaining, Flat, .461 Dia.....	1	04045-73	Cover Gasket	1
04045-33	Screw, .250-20 x 1.000 inch, Thread Form	4	04045-74	O-Ring	1
04045-34	Pump Housing Assembly.....	1	04045-75	O-Ring.....	1
04045-35	Pump, .375 Thick Gerotor.....	1	04045-76	Filter Assembly.....	1
04045-36	Pin, Pump Drive.....	1	04045-77	Piston, Accumulator	1
04045-37	Gauge, Oil Sight	2	04045-78	Spring, Accumulator, Outer	1
04045-38	Elbow, 1/8 Pipe Thd to 1/4 Tube.....	1	04045-79	Spring, Accumulator, Inner.....	1
04045-39	Decal, Drive Shaft Rotation.....	2	04045-80	Seat, Accumulator Spring.....	1
04045-40	Shaft, Pump Drive.....	1	04045-81	Ring, Int. Retaining, 1.526 Inch Free Dia.....	1
04045-41	O-Ring, 2.000 x .062 Inch.....	1			

Reference Numbers 1 thru 81 are on this page.

WARNING

Injury may result if compressed springs are released suddenly. Use the proper equipment to remove springs and spring covers.

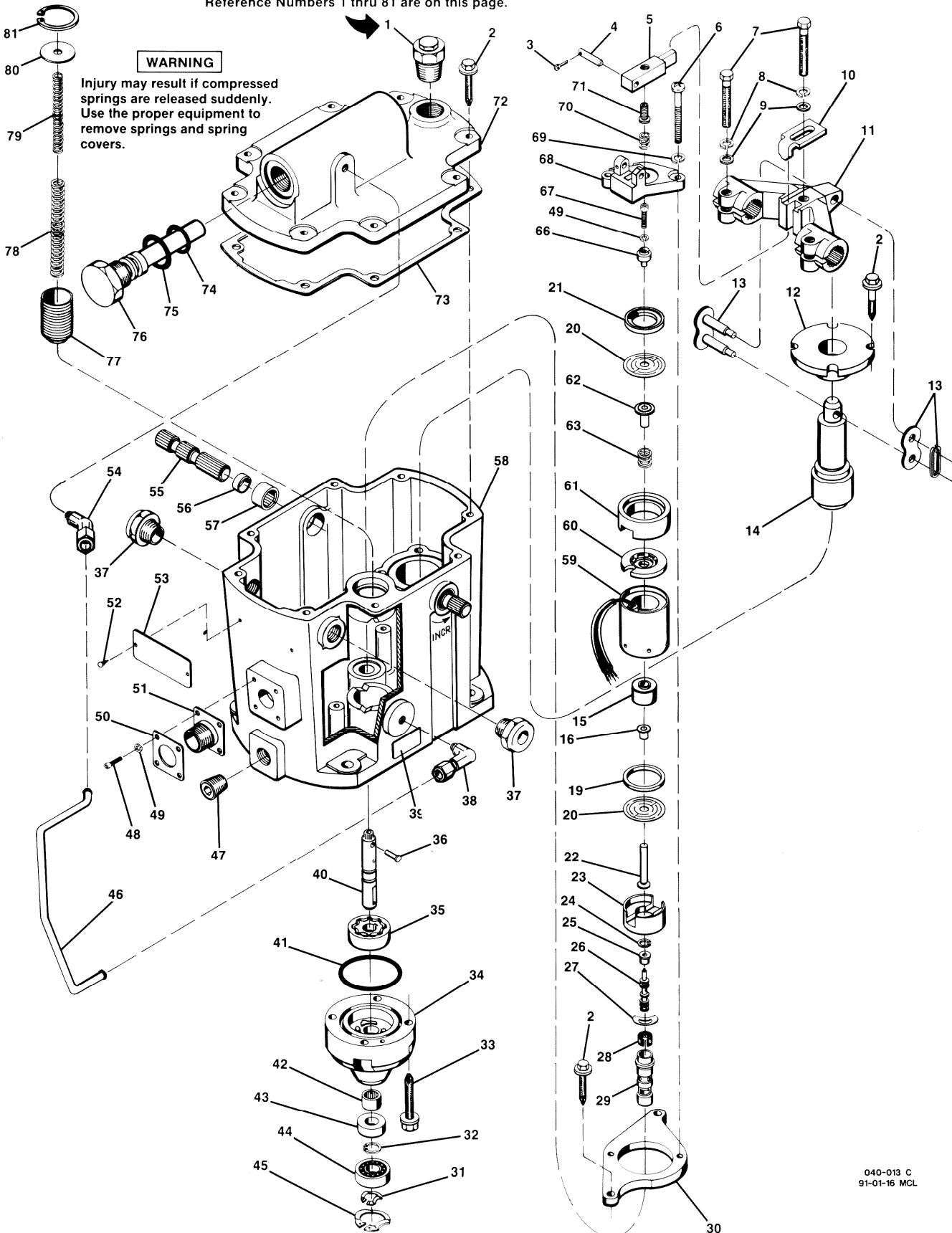

Figure 6-1. TG Exploded View

040-013 C
91-01-16 MCL

Chapter 7.

Service Options

Product Service Options

If you are experiencing problems with the installation, or unsatisfactory performance of a Woodward product, the following options are available:

- Consult the troubleshooting guide in the manual.
- Contact the manufacturer or packager of your system.
- Contact the Woodward Full Service Distributor serving your area.
- Contact Woodward technical assistance (see “How to Contact Woodward” later in this chapter) and discuss your problem. In many cases, your problem can be resolved over the phone. If not, you can select which course of action to pursue based on the available services listed in this chapter.

OEM and Packager Support: Many Woodward controls and control devices are installed into the equipment system and programmed by an Original Equipment Manufacturer (OEM) or Equipment Packager at their factory. In some cases, the programming is password-protected by the OEM or packager, and they are the best source for product service and support. Warranty service for Woodward products shipped with an equipment system should also be handled through the OEM or Packager. Please review your equipment system documentation for details.

Woodward Business Partner Support: Woodward works with and supports a global network of independent business partners whose mission is to serve the users of Woodward controls, as described here:

- A **Full Service Distributor** has the primary responsibility for sales, service, system integration solutions, technical desk support, and aftermarket marketing of standard Woodward products within a specific geographic area and market segment.
- An **Authorized Independent Service Facility (AISF)** provides authorized service that includes repairs, repair parts, and warranty service on Woodward's behalf. Service (not new unit sales) is an AISF's primary mission.
- A **Recognized Engine Retrofitter (RER)** is an independent company that does retrofits and upgrades on reciprocating gas engines and dual-fuel conversions, and can provide the full line of Woodward systems and components for the retrofits and overhauls, emission compliance upgrades, long term service contracts, emergency repairs, etc.
- A **Recognized Turbine Retrofitter (RTR)** is an independent company that does both steam and gas turbine control retrofits and upgrades globally, and can provide the full line of Woodward systems and components for the retrofits and overhauls, long term service contracts, emergency repairs, etc.

A current list of Woodward Business Partners is available at www.woodward.com/support.

Woodward Factory Servicing Options

The following factory options for servicing Woodward products are available through your local Full-Service Distributor or the OEM or Packager of the equipment system, based on the standard Woodward Product and Service Warranty (5-01-1205) that is in effect at the time the product is originally shipped from Woodward or a service is performed:

- Replacement/Exchange (24-hour service)
- Flat Rate Repair
- Flat Rate Remanufacture

Replacement/Exchange: Replacement/Exchange is a premium program designed for the user who is in need of immediate service. It allows you to request and receive a like-new replacement unit in minimum time (usually within 24 hours of the request), providing a suitable unit is available at the time of the request, thereby minimizing costly downtime. This is a flat-rate program and includes the full standard Woodward product warranty (Woodward Product and Service Warranty 5-01-1205).

This option allows you to call your Full-Service Distributor in the event of an unexpected outage, or in advance of a scheduled outage, to request a replacement control unit. If the unit is available at the time of the call, it can usually be shipped out within 24 hours. You replace your field control unit with the like-new replacement and return the field unit to the Full-Service Distributor.

Charges for the Replacement/Exchange service are based on a flat rate plus shipping expenses. You are invoiced the flat rate replacement/exchange charge plus a core charge at the time the replacement unit is shipped. If the core (field unit) is returned within 60 days, a credit for the core charge will be issued.

Flat Rate Repair: Flat Rate Repair is available for the majority of standard products in the field. This program offers you repair service for your products with the advantage of knowing in advance what the cost will be. All repair work carries the standard Woodward service warranty (Woodward Product and Service Warranty 5-01-1205) on replaced parts and labor.

Flat Rate Remanufacture: Flat Rate Remanufacture is very similar to the Flat Rate Repair option with the exception that the unit will be returned to you in “like-new” condition and carry with it the full standard Woodward product warranty (Woodward Product and Service Warranty 5-01-1205). This option is applicable to mechanical products only.

Returning Equipment for Repair

If a control (or any part of an electronic control) is to be returned for repair, please contact your Full-Service Distributor in advance to obtain Return Authorization and shipping instructions.

When shipping the item(s), attach a tag with the following information:

- return number;
- name and location where the control is installed;
- name and phone number of contact person;
- complete Woodward part number(s) and serial number(s);
- description of the problem;
- instructions describing the desired type of repair.

Packing a Control

Use the following materials when returning a complete control:

- protective caps on any connectors;
- antistatic protective bags on all electronic modules;
- packing materials that will not damage the surface of the unit;
- at least 100 mm (4 inches) of tightly packed, industry-approved packing material;
- a packing carton with double walls;
- a strong tape around the outside of the carton for increased strength.

NOTICE

To prevent damage to electronic components caused by improper handling, read and observe the precautions in Woodward manual 82715, *Guide for Handling and Protection of Electronic Controls, Printed Circuit Boards, and Modules*.

Replacement Parts

When ordering replacement parts for controls, include the following information:

- the part number(s) (XXXX-XXXX) that is on the enclosure nameplate;
- the unit serial number, which is also on the nameplate.

Engineering Services

Woodward offers various Engineering Services for our products. For these services, you can contact us by telephone, by email, or through the Woodward website.

- Technical Support
- Product Training
- Field Service

Technical Support is available from your equipment system supplier, your local Full-Service Distributor, or from many of Woodward's worldwide locations, depending upon the product and application. This service can assist you with technical questions or problem solving during the normal business hours of the Woodward location you contact. Emergency assistance is also available during non-business hours by phoning Woodward and stating the urgency of your problem.

Product Training is available as standard classes at many of our worldwide locations. We also offer customized classes, which can be tailored to your needs and can be held at one of our locations or at your site. This training, conducted by experienced personnel, will assure that you will be able to maintain system reliability and availability.

Field Service engineering on-site support is available, depending on the product and location, from many of our worldwide locations or from one of our Full-Service Distributors. The field engineers are experienced both on Woodward products as well as on much of the non-Woodward equipment with which our products interface.

For information on these services, please contact us via telephone, email us, or use our website and reference www.woodward.com/support, and then **Customer Support**.

How to Contact Woodward

For assistance, call one of the following Woodward facilities to obtain the address and phone number of the facility nearest your location where you will be able to get information and service.

Electrical Power Systems		Engine Systems		Turbine Systems	
Facility	Phone Number	Facility	Phone Number	Facility	Phone Number
Australia	+61 (2) 9758 2322	Australia	+61 (2) 9758 2322	Australia	+61 (2) 9758 2322
Brazil	+55 (19) 3708 4800	Brazil	+55 (19) 3708 4800	Brazil	+55 (19) 3708 4800
China	+86 (512) 6762 6727	China	+86 (512) 6762 6727	China	+86 (512) 6762 6727
Germany:		Germany:			
Kempen	+49 (0) 21 52 14 51	Stuttgart	+49 (711) 78954-0		
Stuttgart	+49 (711) 78954-0				
India	+91 (129) 4097100	India	+91 (129) 4097100	India	+91 (129) 4097100
Japan	+81 (43) 213-2191	Japan	+81 (43) 213-2191	Japan	+81 (43) 213-2191
Korea	+82 (51) 636-7080	Korea	+82 (51) 636-7080	Korea	+82 (51) 636-7080
		The Netherlands	+31 (23) 5661111	The Netherlands	+31 (23) 5661111
Poland	+48 12 618 92 00				
United States	+1 (970) 482-5811	United States	+1 (970) 482-5811	United States	+1 (970) 482-5811

You can also contact the Woodward Customer Service Department or consult our worldwide directory on Woodward's website (www.woodward.com/support) for the name of your nearest Woodward distributor or service facility.

For the most current product support and contact information, please refer to the latest version of publication **51337** at www.woodward.com/publications.

Technical Assistance

If you need to telephone for technical assistance, you will need to provide the following information. Please write it down here before phoning:

General

Your Name _____

Site Location _____

Phone Number _____

Fax Number _____

Prime Mover Information

Engine/Turbine Model Number _____

Manufacturer _____

Number of Cylinders (if applicable) _____

Type of Fuel (gas, gaseous, steam, etc) _____

Rating _____

Application _____

Control/Governor Information

Please list all Woodward governors, actuators, and electronic controls in your system:

Woodward Part Number and Revision Letter

Control Description or Governor Type

Serial Number

Woodward Part Number and Revision Letter

Control Description or Governor Type

Serial Number

Woodward Part Number and Revision Letter

Control Description or Governor Type

Serial Number

If you have an electronic or programmable control, please have the adjustment setting positions or the menu settings written down and with you at the time of the call.

Declaration of Incorporation

Woodward Governor Company
1000 E. Drake Road
Fort Collins, Colorado 80525
United States of America

Product: TG Actuators
Part Number: TG10E, TG13E, TG17E

The undersigned hereby declares, on behalf of Woodward Governor Company of Loveland and Fort Collins, Colorado, that the above-referenced product is in conformity with the following EU Directives as they apply to a component:

98/37/EEC (Machinery)

This product is intended to be put into service only upon incorporation into an apparatus/system that itself will meet the requirements of the above Directives and bears the CE mark.

Manufacturer

Signature

Jennifer R. Williams

Full Name

Engineering Project/Process Manager

Position

WGC, Fort Collins, CO, USA

Location

11-01-01

Date

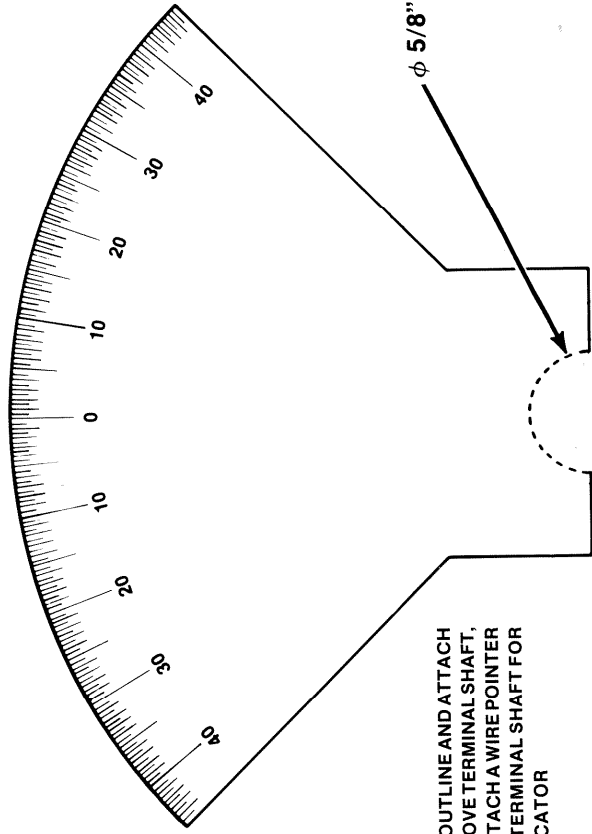

CUT ON OUTLINE AND ATTACH
JUST ABOVE TERMINAL SHAFT,
ALSO ATTACH A WIRE POINTER
TO THE TERMINAL SHAFT FOR
AN INDICATOR

PROTRACTOR

82500-A-316

We appreciate your comments about the content of our publications.

Send comments to: icinfo@woodward.com

Please reference publication **04045E**.



PO Box 1519, Fort Collins CO 80522-1519, USA
1000 East Drake Road, Fort Collins CO 80525, USA
Phone +1 (970) 482-5811 • Fax +1 (970) 498-3058

Email and Website—www.woodward.com

**Woodward has company-owned plants, subsidiaries, and branches,
as well as authorized distributors and other authorized service and sales facilities throughout the world.**

Complete address / phone / fax / email information for all locations is available on our website.